

# **Bruciatori di nafta**

## **Heavy oil burners**

### **Brûleurs fioul lourd**

#### **Schwerölbrenner**

##### **Quemadores de nafta**

Funzionamento bistadio  
Two-stage operation  
Fonctionnement à deux allures  
Zweistufiger Betrieb  
Funcionamiento de dos llama

COD.	MOD.	TYP.
<b>3433823</b>	<b>PRESS 30 N/ECO</b>	<b>626 T</b>
<b>3433824</b>	<b>PRESS 30 N/ECO</b>	<b>626 T</b>
<b>3434623</b>	<b>PRESS 45 N/ECO</b>	<b>627 T</b>
<b>3434624</b>	<b>PRESS 45 N/ECO</b>	<b>627 T</b>

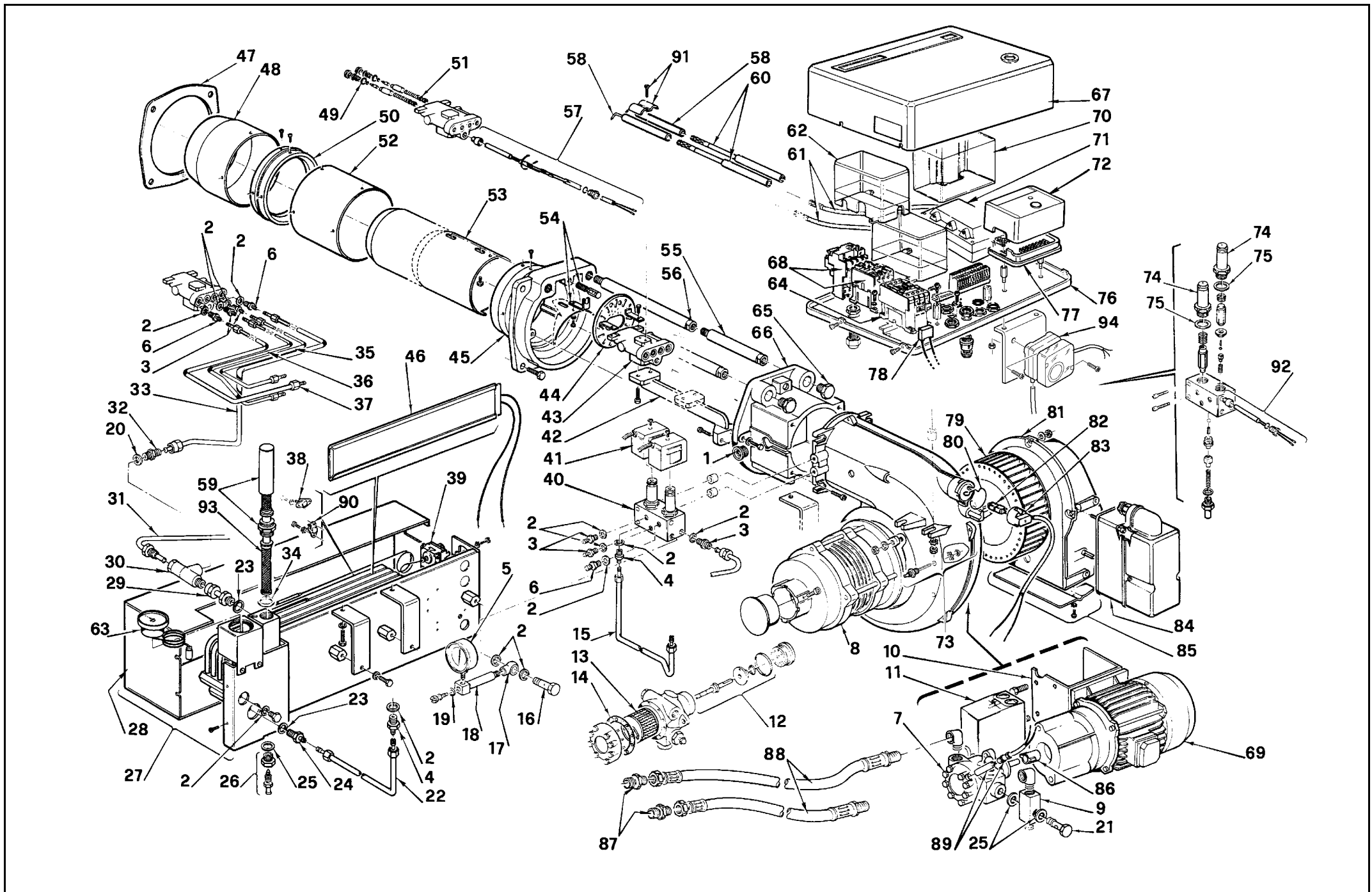

N.	COD.	626 T		627 T		DESCRIZIONE	DESCRIPTION	DESCRIPTION	BESCHREIBUNG	DENOMINACION	MATRICOLA BRUCIATORE BURNER SERIAL NUMBER MATRICULE BRULEUR BRENNER KENN-NUMMER MATRICULA QUEMADORES	RICAMBI CONSIGLIATI ADVISED PARTS RECHANGE CONSEIL EMPFÖHLENE ERSATZTEILE RECAMBIOS A CONSEJADOS
		3433823	3433824 *	3434623	3434624 *							
1	3003464	•	•	•	•	TAPPO	PLUG	BOUCHON A VIS	SCHRAUBSTÖPSEL	TAPA		
2	3007079	•	•	•	•	GUARNIZIONE	SEAL	RONDELLE	METALLDICHTUNG	JUNTA		B
3	3003005	•	•	•	•	RACCORDO	CONNECTOR	MAMELON	NIPPEL	RACORD		C
4	3009081	•	•	•	•	RACCORDO	CONNECTOR	MAMELON	NIPPEL	RACORD		C
5	3006140	•	•	•	•	MANOMETRO	PRESSURE GAUGE	MANOMETRE	MANOMETER	MANÓMETRO		A
6	3006723	•	•	•	•	RACCORDO	CONNECTOR	MAMELON	NIPPEL	RACORD		C
7	3003026	•	•	•	•	POMPA	PUMP	POMPE	PUMPE	BOMBA		B
8	3006716	•	•	•	•	MOTORE	MOTOR	MOTEUR	MOTOR	MOTOR		C
9	3003055	•	•	•	•	RACCORDO	CONNECTOR	MAMELON	NIPPEL	RACORD		C
10	3003560	•	•	•	•	STAFFA	BRACKET	SUPPORT	TRAGERKONSOLE	SOPORTE		
11	3003561	•	•	•	•	AVVIATORE	STARTER	DEMARREUR	ANLASSER	ARRANCADOR		C
12	3000766	•	•	•	•	ORGANO DI TENUTA	PUMP SEAL	ORGANE D'ETANCHEITE	WELLENDICHTUNG	CONNJUNTO ESTANQUIDAD		
13	3006308	•	•	•	•	FILTRO	FILTER	FILTRE	PUMPENFILTER	FILTRO		A
14	3006292	•	•	•	•	GUARNIZIONE	SEAL	JOINT COUVERCLE POMPE	PUMPENDICHTUNG	JUNTA		A
15	3003562	•	•	•	•	TUBO	TUBE	TUYAUTERIE	DRUCKROHR	TUBO		
16	3003006	•	•	•	•	RACCORDO	CONNECTOR	MAMELON	NIPPEL	RACORD		C
17	3006429	•	•	•	•	RACCORDO	CONNECTOR	MAMELON	NIPPEL	RACORD		C
18	3006540	•	•	•	•	VALVOLA	NEEDLE VALVE	ROBINET POINTEAU	NADELVENTIL	VÁLVULA		C
19	3007169	•	•	•	•	ANELLO OR	O RING	JOINT TORIQUE	O-RING	JUNTA TORICA		B
20	3007077	•	•	•	•	GUARNIZIONE	SEAL	RONDELLE	METALLDICHTUNG	JUNTA		B
21	3006184	•	•	•	•	RACCORDO	CONNECTOR	MAMELON	NIPPEL	RACORD		C
22	3003563	•	•	•	•	TUBO	TUBE	TUYAUTERIE	DRUCKROHR	TUBO		
23	3007082	•	•	•	•	GUARNIZIONE	SEAL	RONDELLE	METALLDICHTUNG	JUNTA		B
24	3009084	•	•	•	•	RACCORDO	CONNECTOR	MAMELON	NIPPEL	RACORD		C
25	3007164	•	•	•	•	GUARNIZIONE	SEAL	RONDELLE	METALLDICHTUNG	JUNTA		B
26	3006423	•	•	•	•	VALVOLA DI SCARICO	EXHAUST VALVE	BOUCHON DE PURGE	ENTLEERUNGSVENTIL	VÁLVULA DE ESCAPE		C
27	3003564	•	•	•	•	SERBATOIO	PRE-HEATER	RESERVOIR	ÖLVORWÄRMER	JUNTA PRECALENTADOR		C
28	3003471	•	•	•	•	COPERCHIO	COVER	COUVERCLE	DECKEL	ENVOLVENTE		
29	3003472	•	•	•	•	RACCORDO	CONNECTOR	MAMELON	NIPPEL	RACORD		C
30	3006870	•	•	•	•	VALVOLA ANTIGAS	BACK-PRESSURE VALVE	VANNE ANTIGAZ	GEGENGASBILDUNGVENTIL	VÁLVULA CONTRA-GAS		C
31	3003473	•	•	•	•	TUBO	TUBE	TUYAUTERIE	DRUCKROHR	TUBO		
32	3006720	•	•	•	•	RACCORDO	CONNECTOR	MAMELON	NIPPEL	RACORD		C
33	3003474	•	•	•	•	TUBO	TUBE	TUYAUTERIE	DRUCKROHR	TUBO		
33	3003475	•	•	•	•	TUBO	TUBE	TUYAUTERIE	DRUCKROHR	TUBO		
33	3003476	•	•	•	•	TUBO	TUBE	TUYAUTERIE	DRUCKROHR	TUBO		
33	3003477	•	•	•	•	TUBO	TUBE	TUYAUTERIE	DRUCKROHR	TUBO		
34	3007090	•	•	•	•	GUARNIZIONE	SEAL	RONDELLE	METALLDICHTUNG	JUNTA		B
35	3003013	•	•	•	•	TUBO	TUBE	TUYAUTERIE	DRUCKROHR	TUBO		
35	3003015	•	•	•	•	TUBO	TUBE	TUYAUTERIE	DRUCKROHR	TUBO		
35	3003014	•	•	•	•	TUBO	TUBE	TUYAUTERIE	DRUCKROHR	TUBO		
35	3003016	•	•	•	•	TUBO	TUBE	TUYAUTERIE	DRUCKROHR	TUBO		
36	3003017	•	•	•	•	TUBO	TUBE	TUYAUTERIE	DRUCKROHR	TUBO		
36	3003019	•	•	•	•	TUBO	TUBE	TUYAUTERIE	DRUCKROHR	TUBO		
36	3003018	•	•	•	•	TUBO	TUBE	TUYAUTERIE	DRUCKROHR	TUBO		

N.	COD.	626 T		627 T		DESCRIZIONE	DESCRIPTION	DESCRIPTION	BESCHREIBUNG	DENOMINACION	MATRICOLA BRUCIATORE BURNER SERIAL NUMBER MATRICULE BRULEUR BRENNER KENN-NUMMER MATRICULA QUEMADORES	RICAMBI CONSIGLIATI ADVISED PARTS RECHANGE CONSEIL EMPFOHLENE ERSATZTEILE RECAMBIOS A CONSEJADOS
		3433823	3433824 *	3434623	3434624 *							
36	3003020				•	TUBO	TUBE	TUYAUTERIE	DRUCKROHR	TUBO		
37	3003021	•				TUBO	TUBE	TUYAUTERIE	DRUCKROHR	TUBO		
37	3003023		•			TUBO	TUBE	TUYAUTERIE	DRUCKROHR	TUBO		
37	3003022			•		TUBO	TUBE	TUYAUTERIE	DRUCKROHR	TUBO		
37	3003024				•	TUBO	TUBE	TUYAUTERIE	DRUCKROHR	TUBO		
38	3006065	•	•	•	•	TERMOSTATO DI MASSIMA	HIGHT POINT THERMOSTAT	THERMOSTAT MAXIMAL	THERMOSTAT MAX	TÉRMOSTATO DEL MAX.		B
39	3006444	•	•	•	•	TERMOSTATO	THERMOSTAT	THERMOSTAT	THERMOSTAT	TÉRMOSTATO		B
40	3003503	•	•	•	•	GRUPPO VALVOLE	VALVE ASSEMBLY	GROUPE ELECTROVANNE	MAGNETVENTILBLOCK	CONJUNTO VÁLVULAS		B
41	3003001	•	•	•	•	BOBINA	COIL	BOBINE E.V.	MV-SPULE	BOBINA		B
42	3006418	•				STAFFA CORTA	SHORT BRACKET	SUPPORT COURT	KURZER HALTERUNG	SOPORTE CORTO		
42	3006419		•			STAFFA LUNGA	LONG BRACKET	SUPPORT LONG	LANGE HALTERUNG	SOPORTE LARGO		
42	3006452			•		STAFFA CORTA	SHORT BRACKET	SUPPORT COURT	KURZER HALTERUNG	SOPORTE CORTO		
42	3006453				•	STAFFA LUNGA	LONG BRACKET	SUPPORT LONG	LANGE HALTERUNG	SOPORTE LARGO		
43	3003505	•	•	•	•	POLVERIZZATORE	NOZZLE HOLDER	PULVERISATEUR	DÜSENSTOCK	PORTABOQUILLA		B
44	3005514	•	•			ELICA	DIFFUSER DISC	ACCROCHE FLAMME	STAUSCHEIBE	DISCO ESTABILIZADOR		A
44	3005515			•	•	ELICA	DIFFUSER DISC	ACCROCHE FLAMME	STAUSCHEIBE	DISCO ESTABILIZADOR		A
45	3006421	•	•	•	•	BOCCAGLIO	BLAST TUBE	GUEULARD	BRENNERFLANSCH	TUBO LLAMA		
46	3006067	•	•	•	•	RESISTENZA	RESISTANCE	RESISTANCE	WIDERSTAND	RESISTENCIA		B
47	3005741	•	•	•	•	SCHERMO	FLANGE GASKET	ECRAN THERMIQUE	FLANSCHDICHTUNG	JUNTA AISLANTE		A
48	3006436	•	•			IMBUTO FIAMMA	END CONE	EMBOUT GUEULARD	FLAMMENROHR	TUBO EXTREMO		B
48	3006482			•	•	IMBUTO FIAMMA	END CONE	EMBOUT GUEULARD	FLAMMENROHR	TUBO EXTREMO		B
49	3007025	•	•	•	•	ANELLO OR	O RING	JOINT TORIQUE	O-RING	JUNTA TORICA		B
50	3000567		•	•	•	DENTE	CONNECTION SLEEVE	JONCTION	STAURING	ANILLO LLAMA		
51	3005372	•	•	•	•	GUARNIZIONE	SEAL	RONDELLE	METALLDICHTUNG	JUNTA		B
52	3006440		•	•	•	CILINDRO	SLEEVE	CYLINDRE	ZYLINDER	CILINDRO		C
53	3006437	•				CILINDRO CORTO	SHORT SLEEVE	CYLINDRE COURT	KURZER ZYLINDER	CILINDRO CORTO		C
53	3006438		•			CILINDRO LUNGO	LONG SLEEVE	CYLINDRE LONG	LANGER ZYLINDER	CILINDRO LARGO		C
53	3006485			•	•	CILINDRO CORTO	SHORT SLEEVE	CYLINDRE COURT	KURZER ZYLINDER	CILINDRO CORTO		C
53	3006486				•	CILINDRO LUNGO	LONG SLEEVE	CYLINDRE LONG	LANGER ZYLINDER	CILINDRO LARGO		C
54	3003478	•	•	•	•	GRUPPO AVANZAMENTO	ADJUSTMENT ASSEMBLY	GROUPE ENTRAINEMENT	VORSCHUB HEBELSYSTEM	GRUPO DE AJUSTE		
55	3006496		•	•	•	PROLUNGA PERNO	BAR EXTENSION	RALLONGE DE GLISSIERE	VERLÄNGERUNG	PROLUNGACIÓN GUÍA		
56	3003479	•	•			PERNO	BAR	GLISSIERE	BOLZEN	GUÍA		
56	3003480			•	•	PERNO	BAR	GLISSIERE	BOLZEN	GUÍA		
57	3006022	•	•	•	•	GRUPPO RESISTENZA	HEATER GROUP	GROUPE RESISTANCE	HEIZWIDERSTAND	GRUPO RESISTENCIA		B
58	3004842	•	•	•	•	ELETTRODO	ELECTRODE	ELECTRODE PORCELAINE	ELEKTRODE	ELECTRODO		A
59	3003528	•	•	•	•	FILTRO DOPPIO	DOUBLE FILTER	DOUBLE FILTRE	DOPPEL FILTER	FILTRO		B
60	3000478		•	•	•	PROLUNGA ELETTRODO	ELECTRODE EXTENSION	RALLONGE ELECTRODE	ELEKTRODE VERLÄNGERUNG	PROLUNGACIÓN ELECTRODO		A
61	3003973	•	•	•	•	COLLEGAMENTO	H.T. LEAD	CONNEXION POUR ELECTRODE	VERBINDUNG FÜR ELEKTRODE	CABLE ALTA TENSIÓN		A
62	3003072	•	•	•	•	COPERCHIO	COVER	COUVERCLE	PVC ABDECKUNG	ENVOLVENTE		
63	3006927	•	•	•	•	TERMOMETRO	THERMOMETER	THERMOMETRE	THERMOMETER	TERMÓMETRO		C
64	3003635	•	•	•	•	CONTATTORE	CONTACTOR	CONTACTEUR	SCHÜTZ	TEMPORIZADOR		C
65	3003481	•	•	•	•	VITE	SCREW	VIS	SCHRAUBE	TORNILLO		

\* = Versione Testa Lunga - Long Combustion Head Version - Version Tête Longue - Langer Brennkopf Ausführung - Versión alargado de tubo llama

N.	COD.	626 T		627 T		DESCRIZIONE	DESCRIPTION	DESCRIPTION	BESCHREIBUNG	DENOMINACION	MATRICOLA BRUCIATORE BURNER SERIAL NUMBER MATRICULE BRULEUR BRENNER KENN-NUMMER MATRICULA QUEMADORES	RICAMBI CONSIGLIATI ADVISED PARTS RECHARGE CONSEIL EMPFOHLENE ERSATZTEILE RECAMBIOS A CONSEJADOS
		3433823	3433824 *	3434623	3434624 *							
66	3003482	•	•	•	•	MANICOTTO	MANIFOLD	MANCHON	GASANSCHLUSS	MANGUITO		
67	3003483	•	•	•	•	COPERCHIO	COVER	COUVERCLE	DECKEL	ENVOLVENTE		
68	3003565	•	•	•	•	AVVIATORE	STARTER	DEMARREUR	ANLASSER	AIKLADOR		C
69	3003568	•	•	•	•	MOTORE	MOTOR	MOTEUR	MOTOR	MOTOR		C
70	3003071	•	•	•	•	COPERCHIO	COVER	COUVERCLE	PVC ABDECKUNG	ENVOLVENTE		
71	3012164	•	•	•	•	TRASFORMATORE	TRANSFORMER	TRANSFORMATEUR	ZÜNDTRANSFORMATOR	TRANSFORMADOR		B
72	3013071	•	•	•	•	APPARECCHIATURA	CONTROL BOX	BOITE DE CONTROLE	STEUERGERÄT	CAJA CONTROL		B
73	3003891	•	•	•	•	RACCORDO PRESA ARIA	AIR PRESSURE SENSOR	GROUP RACCORD PRIS AIR	LUFTDRUCK SONDE	CONEXIÓN TOMA DEL AIRE		C
74	3005392	•	•	•	•	GUAINA	ARMATURE SLEEVE	GAINE E.V.	MV-HÜLSE	VÁLVULA		
75	3007081	•	•	•	•	GUARNIZIONE	SEAL	RONDELLE	METALLDICHTUNG	JUNTA		B
76	3012170	•	•	•	•	MENSOLA	BASE PLATE	PLAQUE DE SUPPORT	GRUNDPLATTE	SOPORTE		
77	3003784	•	•	•	•	MORSETTIERA	CONTROL BOX BASE	SOCLE	STECKSOCKEL	ZOCALO CAJA CONTROL		C
78	3002305	•	•	•	•	SOPPRESSORE	DAMPER	CONDENSATEUR	FUNKENTSTÖRUNG	SUPRESOR		
79	3005443	•	•	•	•	GIRANTE	FAN	TURBINE	GEBLÄSERAD	TURBINA		C
80	3003325	•	•	•	•	FERMO	SPRING LOCK	RESSORT D'APPUI	SICHERUNGSFEDER	DETENCION		
81	3003385	•	•	•	•	BOCCA D'ASPIRAZIONE	AIR INTAKE	BOITIER D'ASPIRATION	ANSAUGÖFFNUNG	BOCA ASPIRACION		
81	3003361	•	•	•	•	BOCCA D'ASPIRAZIONE	AIR INTAKE	BOITIER D'ASPIRATION	ANSAUGÖFFNUNG	BOCA ASPIRACION		
82	3002280	•	•	•	•	FOTORESISTENZA	P.E. CELL	CELLULE	FOTOWIDERSTAND	FOTORESISTENCIA		A
83	3006441	•	•	•	•	PRESA	HOLDER	PRISE CELLULE	SOCKEL	CONECTOR		C
84	3006311	•	•	•	•	SERVOMOTORE	SERVOMOTOR	SERVOMOTEUR	STELLMOTOR	SERVOMOTOR		B
85	3003316	•	•	•	•	GRUPPO SERRANDA	AIR DAMPER ASSEMBLY	GROUPE VOLET AIR	LUFTKLAPPE	REGISTRO AIRE		
86	3003557	•	•	•	•	GIUNTO	JOINT	ACCOUPLMENT	KUPPLUNG	CONJUNTO		A
87	3009040	•	•	•	•	RACCORDO	CONNECTOR	MAMELON	NIPPEL	RACORD		C
88	3009063	•	•	•	•	TUBO FLESSIBILE	FLEXIBLE OIL LINE	FLEXIBLE	SCHLAUCH	TUBO FLEXIBILE		A
89	3003570	•	•	•	•	GRUPPO RESISTENZA	HEATER GROUP	GROUPE RESISTANCE	HEIZWIDERSTAND	GRUPO RESISTENCIA		B
90	3012421	•	•	•	•	TERMOSTATO DI MINIMA	LOW POINT THERMOSTAT	THERMOSTAT MINIMAL	THERMOSTAT MIN.	TERMÓSTATO DEL MINIM		A
91	3003495	•	•	•	•	CAVALLOTTO	U BOLT	CAVALIER	BÜGELBOLZEN	FIJACION ELECTRODO		
92	3003618	•	•	•	•	RESISTENZA	RESISTANCE	RESISTANCE	WIDERSTAND	RESISTENCIA		B
93	3003694	•	•	•	•	FILTRO	FILTER	FILTRE	FILTER	FILTRO		B
94	3007444	•	•	•	•	PRESSOSTATO ARIA	AIR PRESSURE SWITCH	PRESSOSTAT AIR	LUFTDRUCKWÄCHTER	PRESOSTATO DEL AIRE		A

\* = Versione Testa Lunga - Long Combustion Head Version - Version Tête Longue - Langer Brennkopf Ausführung - Versión alargado de tubo llama

\*\*

A = Ricambi per dotazione minima - Spare parts for minimum fittings - Pièces détachées pour équipement minimum - Ersatzteile für minimale Ausstattung - Recambios para equipamiento mínimo

A+B = Ricambi per dotazione base di sicurezza - Spare parts for basic safety fittings - Pièces détachées pour équipement standard de sécurité - Ersatzteile für Sicherheitsgrundausrüstung - Recambios para equipamiento básico de seguridad

A+B+C = Ricambi per dotazione estesa di sicurezza - Spare parts for extended safety fittings - Pièces détachées pour équipement complet de sécurité - Ersatzteile für erweiterte Sicherheitsausstattung - Recambios para equipamiento general de seguridad







RIELLO S.p.A.  
I - 37048 San Pietro di Legnago (VR)  
Tel.: +39.0442.630111  
[http:// www.rielloburners.com](http://www.rielloburners.com)